

AAMA 508 TEST REPORT

Rendered to:

ALLIED METAL

PRODUCT TYPE: Pressure Equalized Rain Screen System

Report No.: 82368.01-109-44
Test Date: 06/11/08
Through: 03/27/09
Report Date: 04/09/09
Expiration Date: 03/27/13

AAMA 508 TEST REPORT

Rendered to:

ALLIED METAL
3114 Tonnelle Avenue
North Bergen, New Jersey 07047

Report No.: 82368.01-109-44
Test Date: 06/11/08
Through: 03/27/09
Report Date: 04/09/09
Expiration Date: 03/27/13

Product Type: Pressure Equalized Rain Screen System

Project Summary: Architectural Testing, Inc. was contracted by Allied Metal to perform testing in accordance with AAMA 508-07, *Voluntary Test Method and Specification for Pressure Equalized Rain Screen Wall Cladding Systems*. General construction details and test results are included herein. The sample was provided by the client.

Test Methods:

Air Infiltration: ASTM E 283-04, *Standard Test Method for Determining the Rate of Air Leakage Through Exterior Windows, Curtain Walls, and Doors Under Specified Pressure Differences Across the Specimen*. Testing was conducted at 1.57 psf positive static air pressure difference.

Cyclic Static Air Pressure Differential: ASTM E 1233-00, *Standard Test Method for Structural Performance of Exterior Windows, Curtain Walls, and Doors by Cyclic Static Air Pressure Differential*. Testing was conducted at 25.0 psf in 100 three-second cycles.

Static Pressure Water Resistance: ASTM E 331-00, *Standard Test Method for Water Penetration of Exterior Windows, Curtain Walls, and Doors by Uniform Static Air Pressure Difference*. Testing was conducted at 15.0 psf positive static air pressure difference for a 15 minute duration. Water was applied to the mock-up at a minimum rate of 5 gal/ft²/hr.

Dynamic Pressure Water Resistance: AAMA 501.1-05, *Standard Test Method for Exterior Windows, Curtain Walls, and Doors for Water Penetration Using Dynamic Pressure*. Testing was conducted with a dynamic pressure equivalent of 15.0 psf for a 15 minute duration. Water was applied to the mock-up at a minimum rate of 5 gal/ft²/hr.

Test Specimen Description:

Overall Size: 96" wide by 96" high

Top Panel Sizes (2): 46-7/8" wide by 46-7/8" high

Bottom Panel Size: 94-3/4" wide by 46-7/8" high

Rain Screen Construction: The wall was constructed of three 4mm (0.160") thick aluminum composite panels. The aluminum composite panels were constructed of two sheets of 0.025" thick aluminum separated by a polypropylene core material. The panels utilized a "J" bend on all sides and the corners were sealed with silicone. The panels utilized 3/16" wide by 3/4" long weepslots on the bottoms of each panel located 4-1/4" from each end and spaced 6" on center. The top corners of the panels were secured with a 1-3/4" wide by 1-3/4", 0.090" thick 45° aluminum triangle and were secured with two #8 x 3/4" long pancake top edge screws. An extruded aluminum clip was utilized at the horizontal and vertical center joints and was secured with 1/4" x 2" long hex top edge self-tapping screws, through the lexan into the steel studs. The panels utilized a snap-in "J" clip on the bottom edge and exterior edges of the bottom panel and top edge and exterior edges of the top panels. The panels utilized a "Z" snap-in clip on the top edge and interior edges of the bottom panels and bottom edge and interior edges of the top panels. The "Z" clips at the bottom edge of the top panels also utilized a 1/2" high with a 1-5/8" long lateral bend with a 1/2" high vertical bend, 0.030" thick aluminum "Z" plate creating a 1/8" gap between the panel and the "Z" plate. The "J" clips, "Z" clips, and "Z" plate were secured to the panels with #8 x 1/2" long hex top edge self-tapping screws located 4" from each end and spaced 16" on center. The bottom panel utilized a 0.075" thick aluminum "Z" plate with a closed cell foam baffle between the "Z" plate and the panel. The "Z" plate utilized 1/4" weepholes located 3-1/2" from each end and spaced 12" on center. The "Z" plate was secured with the same fasteners as the bottom perimeter screws and each end was sealed with silicone. The perimeter "J" clips were fastened to the steel studs with 1/4" x 2" long hex top edge self-tapping screws located 4" from each end and spaced 16" on center.

Test Set-Up: An 8' wide by 8' high steel studded wall was constructed with 14 gauge steel studs secured to the top and bottom steel track with #12 x 1" long pancake head self-tapping screws on the interior and pop-riveted on the exterior. The steel studs were spaced 16" on center inside a 2x10 wood buck. The stud wall was covered with a 1/4" thick sheet of clear lexan sealed and secured to the exterior of the wall to simulate an air/water barrier. The wall panel system was then installed onto the lexan in a manner consistent with normal construction procedures for the system. The lexan was calibrated to a pre-determined air leakage rate by drilling 1/8" diameter holes in the backside of the acrylic, in a uniform pattern, making sure to create an even pressure drop and leakage rate across the wall and in each quadrant. The exterior and interior of the test unit was sealed with silicone to the wood buck.

Test Results: The following results have been recorded:

<u>Title of Test - Test Method</u>	<u>Results</u>	<u>Allowed</u>
Air Infiltration per ASTM E 283 1.57 psf (25 mph)	0.12 cfm/ft ²	0.11 cfm/ft ² min. 0.13 cfm/ft ² max.

Observations: *The calibrated leakage was achieved with seventy six 1/8" diameter holes drilled through the lexan.*

Pressure Cycling per ASTM E 1233 100 cycles from 5.0 psf to 25.0 psf	<0.08 sec. PASS	0.08 sec.
---	--------------------	-----------

See Pressure Cycling graph in Appendix A.

Observations: *Pressure tap was attached through air barrier at center point of the bottom panel and the center of the interior right top panel.*

Water Penetration per ASTM E 331 6.24 psf	No leakage PASS	3.2 ft ²
--	--------------------	---------------------

Observations: *No leakage.*

Water Penetration per AAMA 501.1 15.05 psf	1.52 ft ² PASS	3.2 ft ²
---	------------------------------	---------------------

Observations: *Water percolated on the lexan.*

Test Equipment:

- Computerized control panel to run positive pressures, cyclic pressures, and measure air leakage rates.
- Structural test chamber to mount the test wall, as to evaluate the performance of the wall panel system for static and cyclic pressures, as well as water penetration. The wall was situated such that the interior side of the polycarbonate test wall was accessible to observe air and water leakage.
- Dynamic wind generator to create a wind pressure to test the wall panel system for dynamic water penetration.
- Computerized data management equipment to read, log, and graph differential pressures.

Test Witnesses: The following representatives witnessed all or part of the testing:

<u>Name</u>	<u>Company</u>
Jeremy R. Bender	Architectural Testing, Inc.
Jeramie D. Grabosch	Architectural Testing, Inc.
Emily C. Riley	Architectural Testing, Inc.
Aaron M. Shultz	Architectural Testing, Inc.
Ken R. Stough	Architectural Testing, Inc.
Eric M. Brennan	Architectural Testing, Inc.
Thomas Lawlor	Architectural Testing, Inc.
Michael D. Stremmel, P.E.	Architectural Testing, Inc.
Russell W. Clark	Architectural Testing, Inc.

Detailed drawings, data sheets, representative samples of test specimens, a copy of this report, or other pertinent project documentation will be retained by Architectural Testing, Inc. for a period of four years from the original test date. At the end of this retention period, such materials shall be discarded without notice and the service life of this report will expire.

Results obtained are tested values and were secured by using the designated test methods. This report does not constitute certification of this product nor an opinion or endorsement by this laboratory. It is the exclusive property of the client so named herein and relates only to the specimen(s) tested. This report may not be reproduced, except in full, without the written approval of Architectural Testing, Inc.

For ARCHITECTURAL TESTING, INC.

Russell W. Clark
Technician

Michael D. Stremmel, P.E.
Senior Project Engineer

RWC:dem

Attachments (pages): This report is complete only when all attachments listed are included.

Appendix-A: Graph (1)

Appendix-B: Drawings (2)

Revision Log

<u>Rev. #</u>	<u>Date</u>	<u>Page(s)</u>	<u>Revision(s)</u>
0	04/09/09	N/A	Original report issue

Appendix A

Graph

AAMA 508 Pressure Cycling

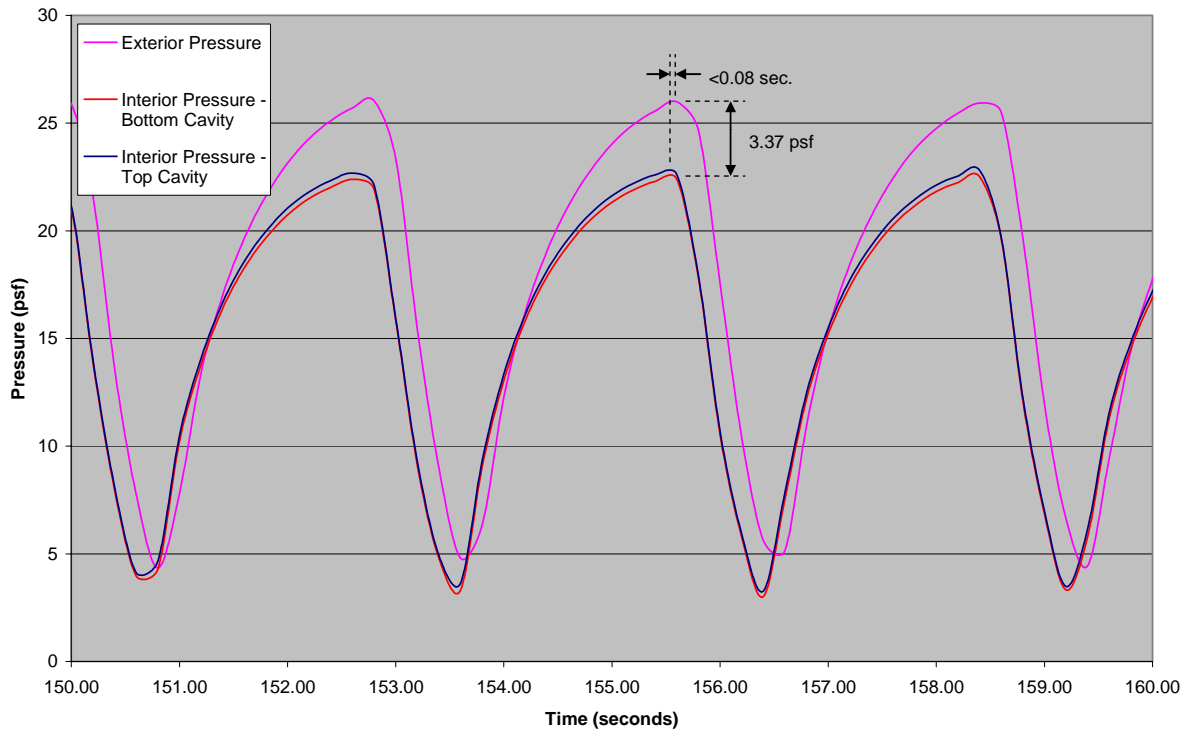

Appendix B

Drawings

PLAN VIEW

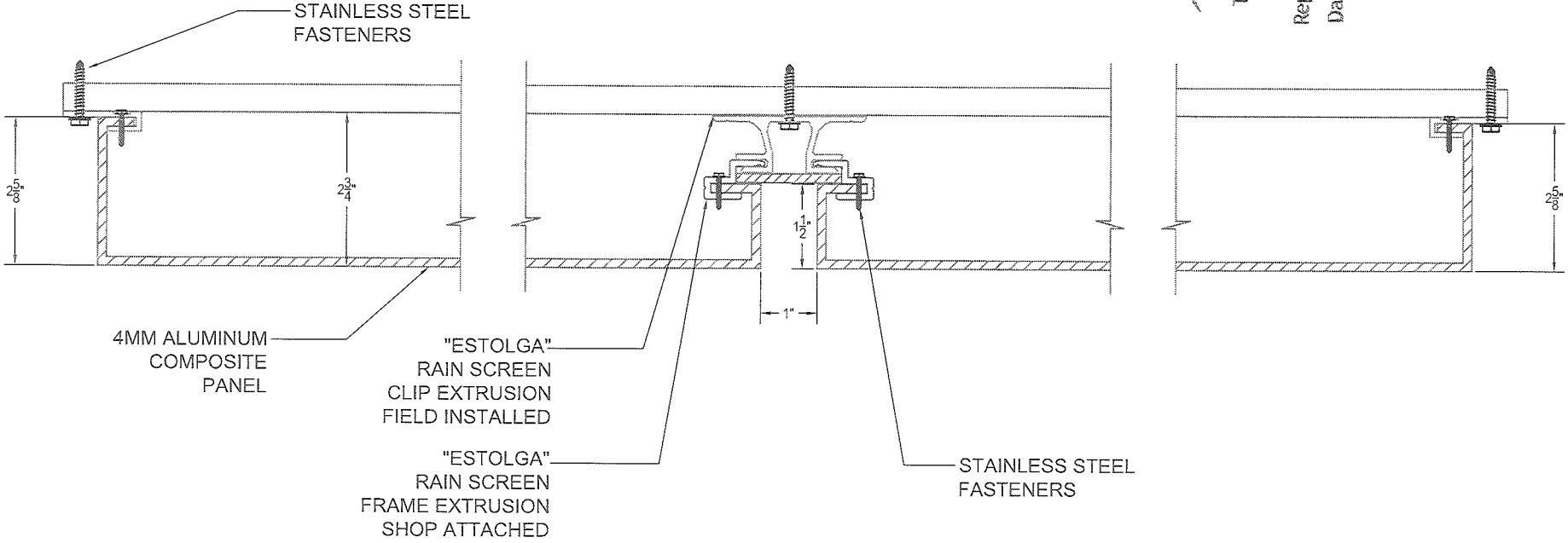

Architectural Testing

Test sample complies with these details. Deviations are noted.

Report# 8236801-109-44
 Date 4/19/09 Tech PL/ode